

TM-2-4F-PA0 Torque Motor

Electrical specifications

Winding code : PA	Symbol	Unit	Water cooling
Continuous torque	T_c	Nm	411
Continuous current	I_c	A_{rms}	18
Stall torque	T_s	Nm	334
Stall current	I_s	A_{rms}	14.4
Peak torque(for 1sec.)	T_p	Nm	780
Peak current(for 1sec.)	I_p	A_{rms}	37.5
Torque constant	K_t	Nm/Arms	23.9
Electrical time constant	T_e	ms	2.8
Resistance (line to line at 25°C)	R_{25}	Ω	8.7
Inductance (line to line)	L	mH	24.3
Number of poles	2p		44
Back emf constant (line to line)	K_v	Vrms/rad/s	13.8
Motor constant (at 25°C)	K_m	Nm/ \sqrt{W}	6.59
Thermal resistance	R_{th}	K/W	0.025
Thermal sensor			PTC SNM100+SNM130+Pt1000
Max. DC BUS		V_{DC}	750
Inertia of rotor	J	kgm^2	0.045
Thermal time constant	T_{th}	s	62
Max. continuous power dissipation	P_c	W	5968
Max. peak power dissipation	P_p	W	25903
Rated speed(at 600VDC)		rpm	162

Mechanical specifications

	Symbol	Unit	Water cooling
Mass of rotor	M_r	kg	7.6
Mass of stator	M_s	kg	22.2
Height of stator	H_s	mm	190
Height of rotor	H_r	mm	151
Length of rotor centring fit	H	mm	15
Water temperature difference for P_c	$\Delta\theta$	K	5
Minimum water flow	q	l/min	17.1
Max. pressure drop	Δp	bar	2

T-N curve

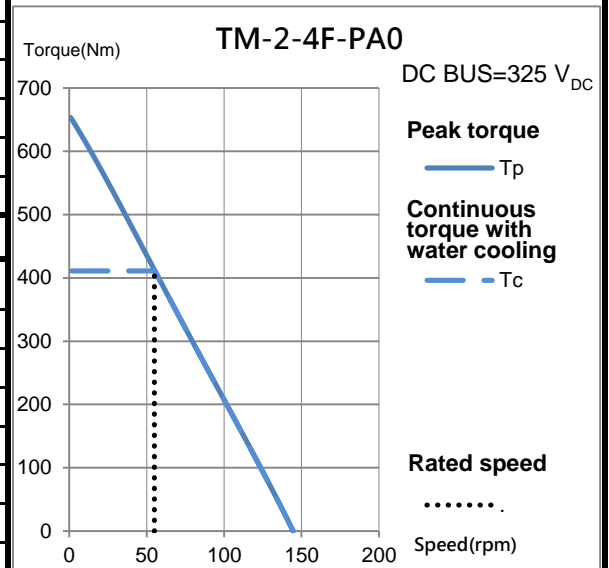
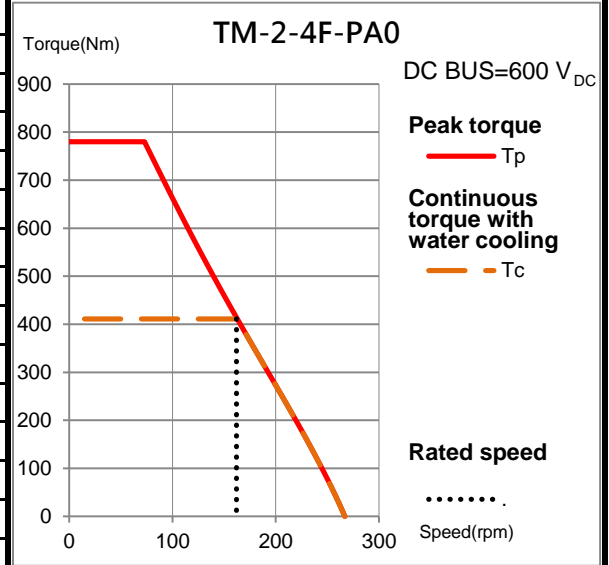

Thermal sensor

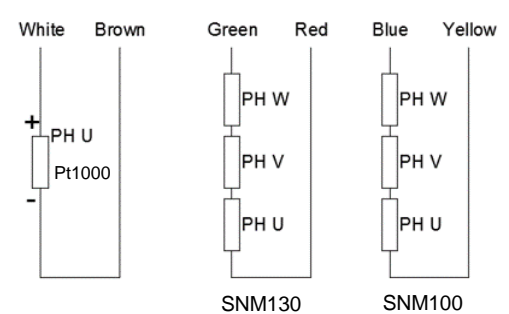
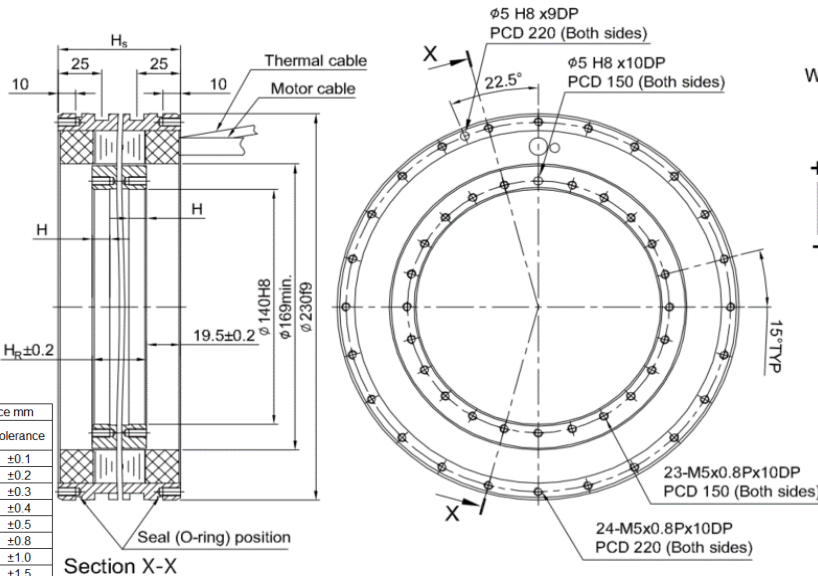

General tolerance mm	
Nominal dimension	Tolerance
~ 6	±0.1
> 6 ~ 30	±0.2
> 30 ~ 120	±0.3
> 120 ~ 300	±0.4
> 300 ~ 600	±0.5
> 600 ~ 1200	±0.8
> 1200 ~ 2400	±1.0
> 2400	±1.5

Motor wire table	
Color or wire no.	Signal
U/L1	PH U
V/L2	PH V
W/L3	PH W
Green/Yellow	GND

Except dimensions, all the specifications in the table are in ±10% of tolerance

Version: 2.00

This drawing is only for reference, detail dimensions please refer to approval drawing.

Date: 2020/10/23